

**WG16032A** Graphic 160x32 dots

**Dimension drawing**

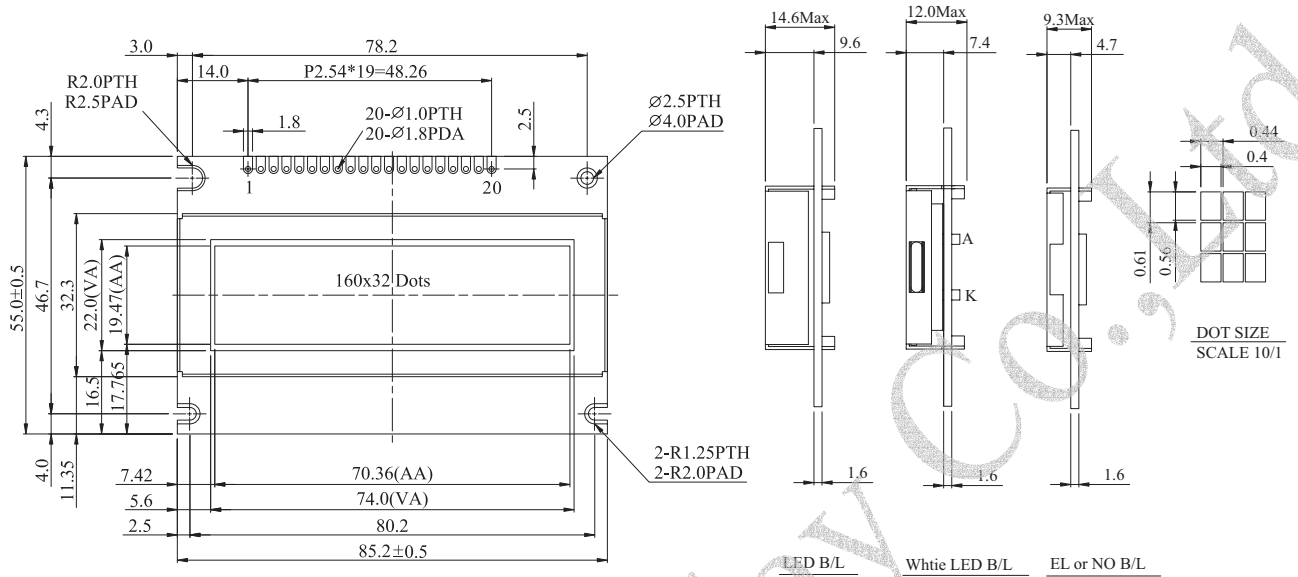

Graphic type

**Feature**

1. Available for External oscilation 2KHz
2. Epson-SED 1520,or equivalent
3. 1/32 duty cycle
4. N.V. optional for +3V power supply

**Mechanical Data**

Item	Standard Value	Unit
Module Dimension	85.2 x 55.0	mm
Viewing Area	74 x 22.0	mm
Mounting hole	80.2 x 46.7	mm
Dot Pitch	0.44 x 0.61	mm

Pin NO.	Symbol	Function
1	Vss	GND
2	Vdd	(+5V)
3	Vc	Contrast Adjustment
4	Ao	H →Data L →Instruction
5	CS1	CS1=0,CS2=0 Select U1 CS1=1,CS2=0 Select U2
6	CS2	CS1=0,CS2=1 Select U3
7	CL	External clock 2KHz
8	E	Enable Signal
9	R/W	H: read data L: write data
10	DB0	Data bus line
11	DB1	Data bus line
12	DB2	Data bus line
13	DB3	Data bus line
14	DB4	Data bus line
15	DB5	Data bus line
16	DB6	Data bus line
17	DB7	Data bus line
18	RES	H →L Reset the LCM
19	A	Power supply for LED B/L(+4.2V)
20	K	Power supply for LED B/L(0V)

**Absolute Maximum Rating**

Item	Symbol	Standard Value			Unit
		min.	typ.	max.	
Power Supply	VDD-VSS	4.75	5	5.25	V
Input Voltage	VI	0	---	VDD	V

Note : VSS=0 Volt, VDD=5.0 Volt.

**Electronical Characteristics**

Item	Symbol	Condition	Standard Value			Unit
			min.	typ.	max.	
Input Voltage	VDD	VDD=+5V	4.5	5.0	5.5	V
Supply Current	IDD	VDD=5V	---	1.0	1.4	mA
Recommended LC Driving Voltage for Normal Temp. Version module	VDD-V0	-20°C	5.8	6.0	6.2	V
		0°C	5.6	5.8	6.0	
		25°C	5.3	5.5	5.7	
		50°C	5.1	5.3	5.5	
LED Forward Voltage	VF	25°C	---	4.2	4.6	V
		70°C	---	4.8	5.0	
LED Forward Current	IF	25°C	---	180	360	mA
EL Power Supply Current	IEL	Vel=110VAC;400Hz	---	---	5.0	mA